

LOC		DIST		P		ZONE		LTR		REVISIONS		DATE	APPD
FT	0									M	REVISE PER ECN 063B-0100-00	26APR00	SU/MC

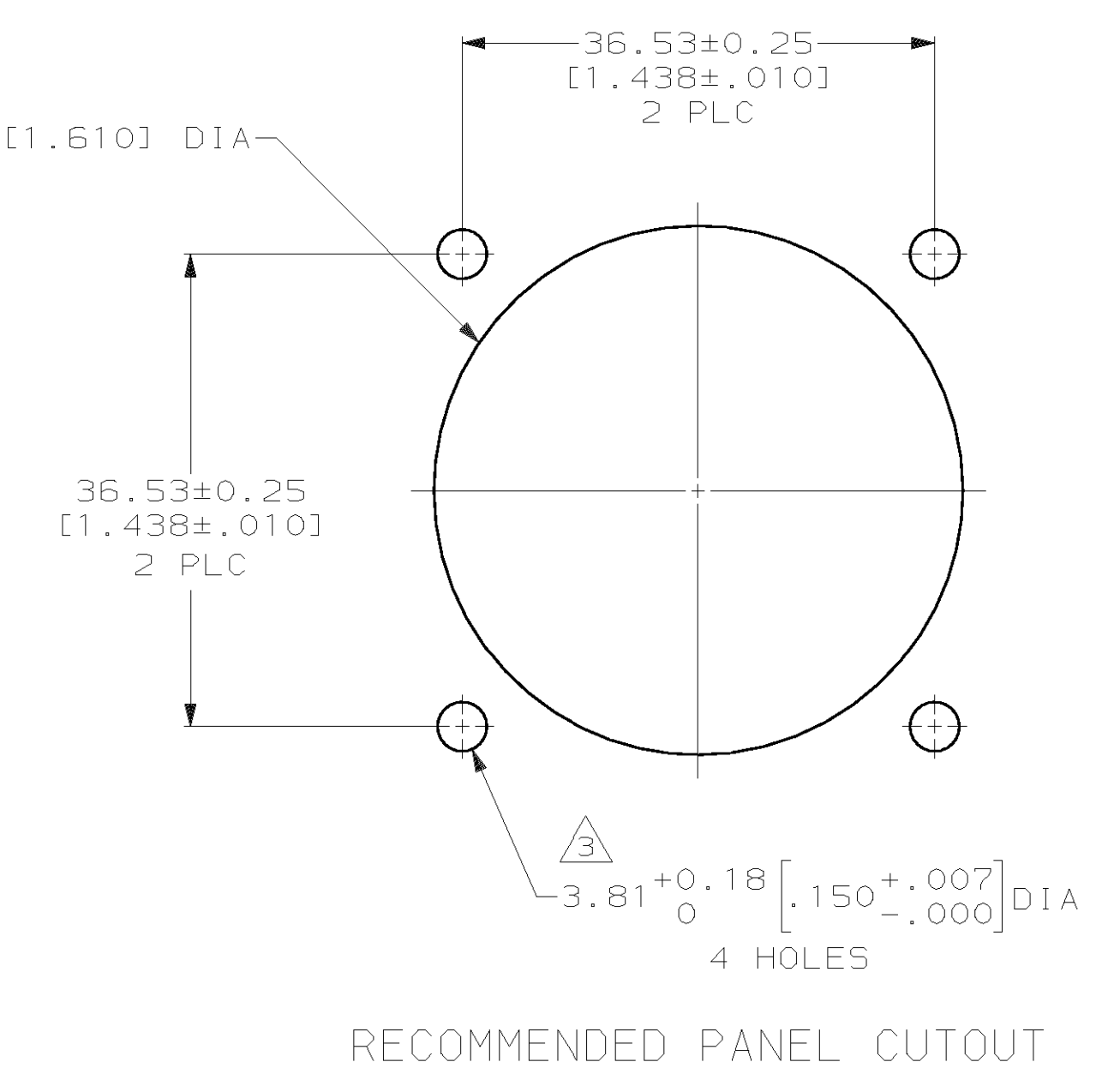

DETAIL A

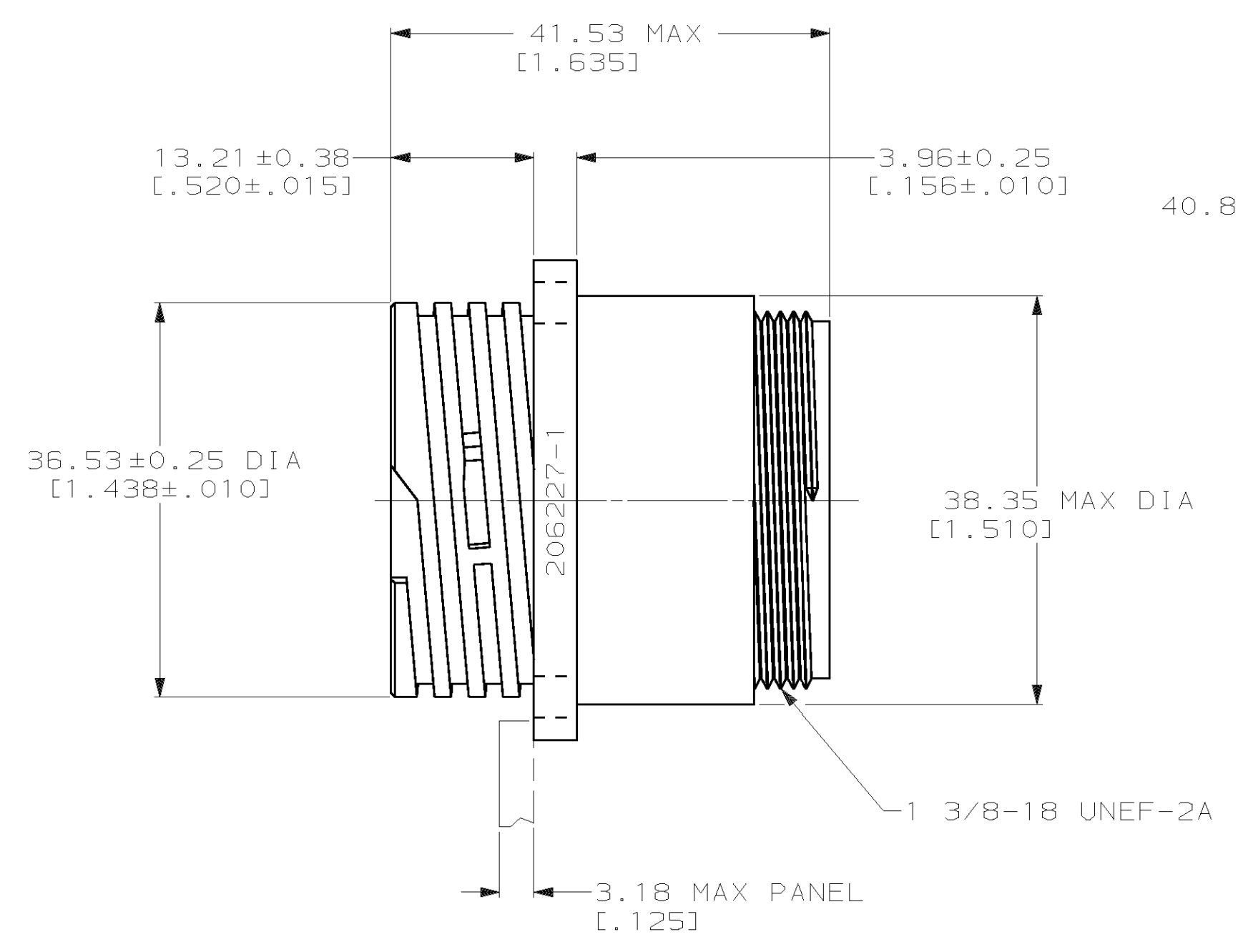
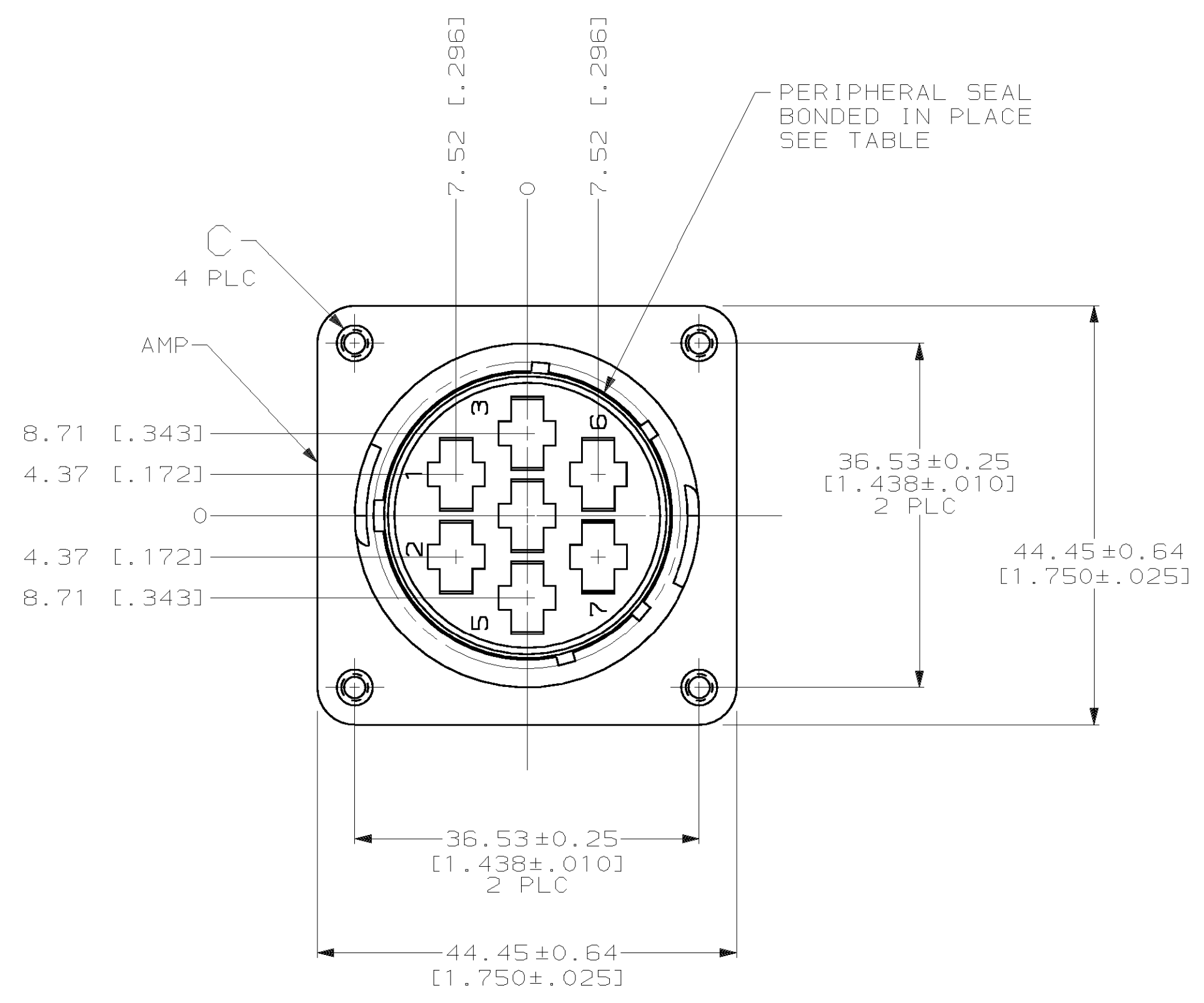
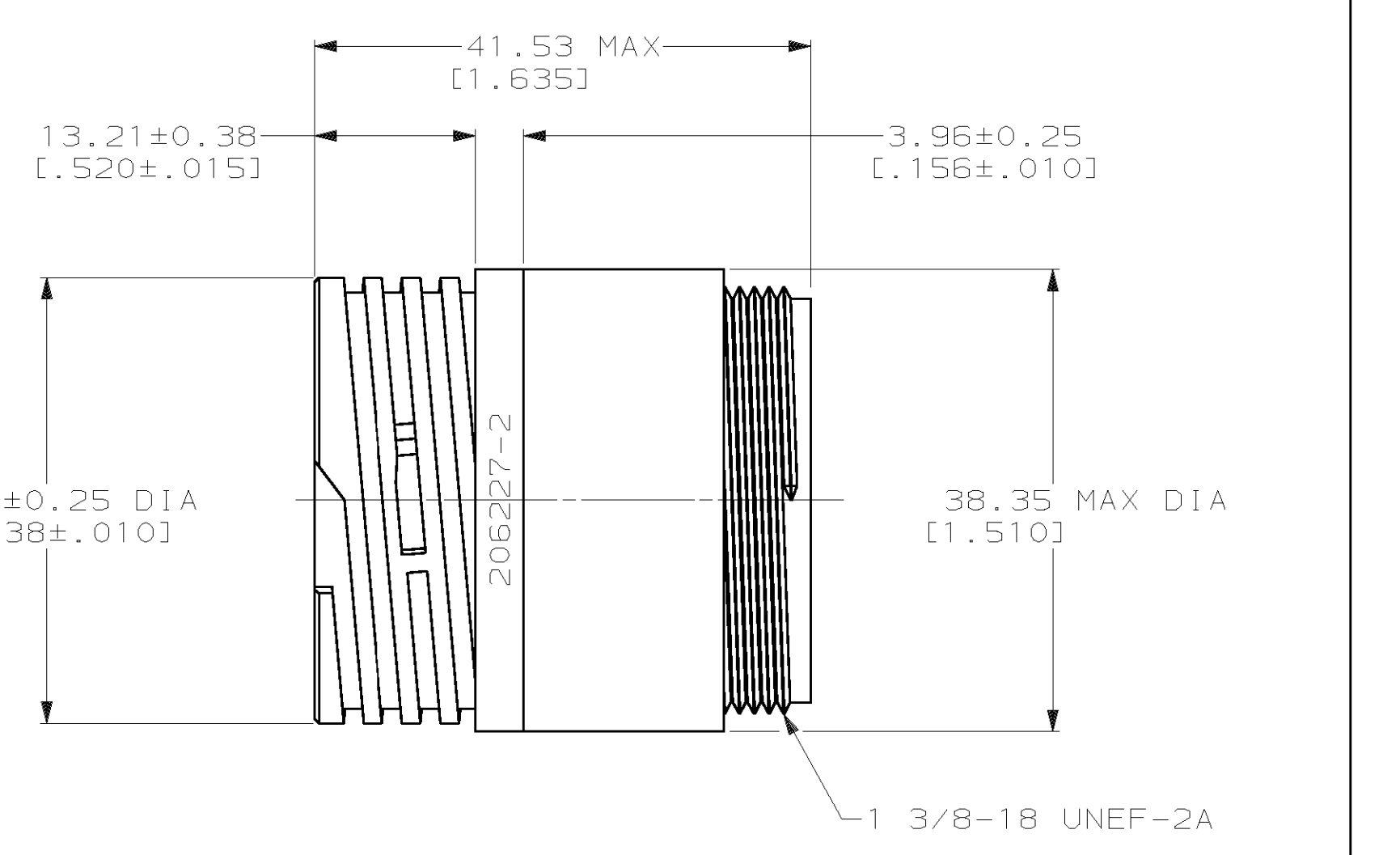
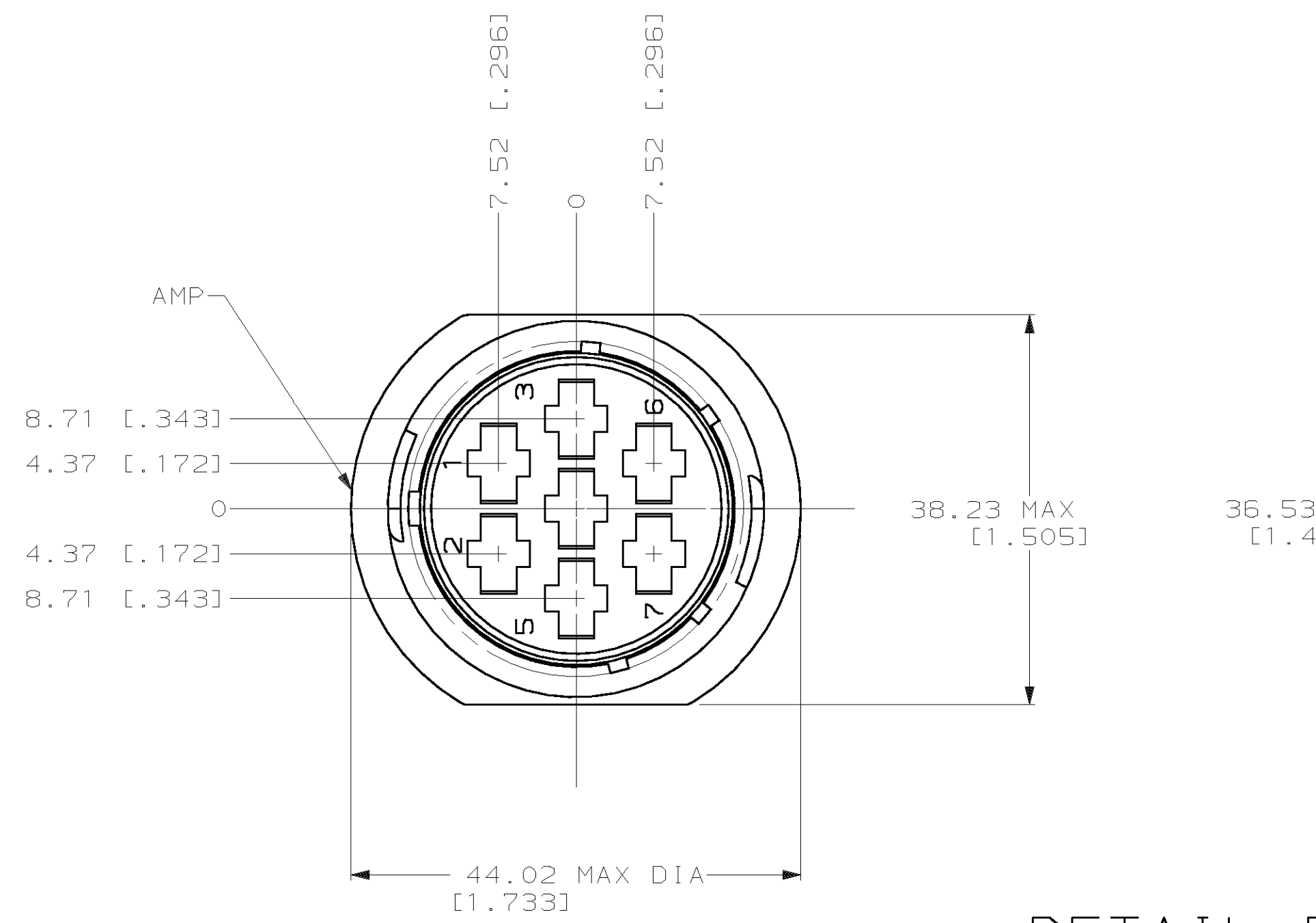

DETAIL B

4-40 THREADED INSERTS	NO	A	206227-6
3.81±0.08 [.150±.003]	YES	A	206227-5
3.81±0.08 [.150±.003]	NO	B	206227-2
3.81±0.08 [.150±.003]	NO	A	206227-1

C	PERIPHERAL SEAL	SEE DETAIL	PART NUMBER
			PART NO

1. CAVITY IDENTIFICATION ON FRONT AND REAR FACE.
  2. WILL ACCEPT SEVEN (7) TYPE XII SOCKET CONTACTS.
- ③ #4 FASTENER RECOMMENDED FOR MOUNTING.

DO NOT SCALE PRINT. UNLESS SPECIFIED DIMENSIONS IN mm [INCHES] TOLERANCES ON:	DR 05/31/94 D.HARDY	AMP Incorporated Harrisburg, PA 17105-3508
2 PLC DEC ±0.13 [.005]	CHK 06/08/94 W.G.LENKER	
3 PLC DEC ± - ANGLES ± -	APPD 07/13/94 A.FRANTUM	
MATERIAL	APPD 07/13/94 A.FRANTUM	NAME
NYLON, BLACK	PRODUCT SPEC 108-10024	RECEPTACLE HOUSING, REVERSE SEX, SHELL SIZE 23, CPC
FINISH	APPLICATION SPEC	SIZE
-	-	D
WEIGHT	-	CAGE CODE
		00779
		DRAWING NO
		G-206227
		SCALE
		2:1
		SHEET
		1 OF 1

THIS DRAWING IS A CONTROLLED DOCUMENT FOR AMP INCORPORATED. IT IS SUBJECT TO CHANGE AND THE CONTROLLING ENGINEERING ORGANIZATION SHOULD BE CONTACTED FOR THE LATEST REVISION.